







Maniglia porte passeggeri - Passengers' door handle

P.630

-  **Materiale - Material**
Poliammide fibra vetro + anti-UV
Glass fibre polyamide + anti-UV
-  **Colore - Colour**
Nero - Black
-  **Pezzi confezione - Package items**
10 pezzi - pieces
-  **Volume confezione - Package volume**
22 dm³
-  **Peso confezione - Package weight**
12.000 g



SPO **Ricambi - Spare parts only**
vedi sezione tecnica - see technical section

 **Accessori - Accessories**
vedi sezione tecnica - see technical section

 **Temp. di esercizio - Working temp.**
-10/+120 °C

LEX **Normative - Norms**
R107.8; R118.3; FMVSS 302; ISO 3795; REACH; ROHS; CMR.
More info on page A4-A5 and website on "Directives and regulations" area.



P.630	m		epn		e	
	manual	m (con ritorno autom. pomello interno) manual (with automatic return of doorknob)	electropneumatic	electric	e (con ritorno autom. pomello interno) electric (with automatic return of doorknob)	
	Cod.	Cod.	Cod.	Cod.	Cod.	Cod.
J1	 69502	No	69552	69562	69542	
J2	 69512	69532	No	69572	No	

P.630

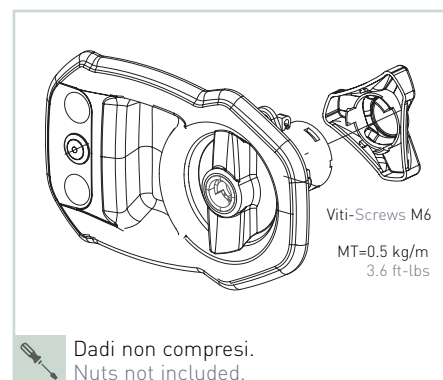
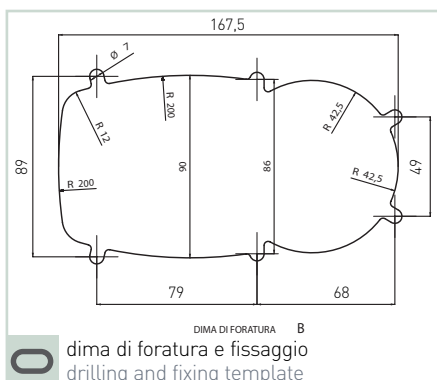
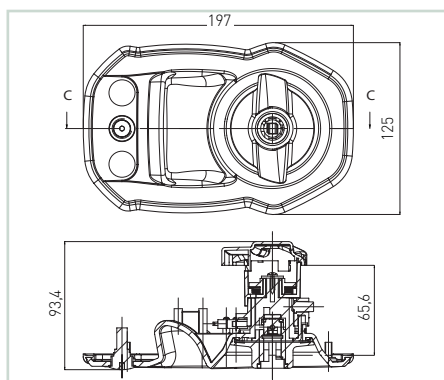

■ Inserimento - Assembly P474

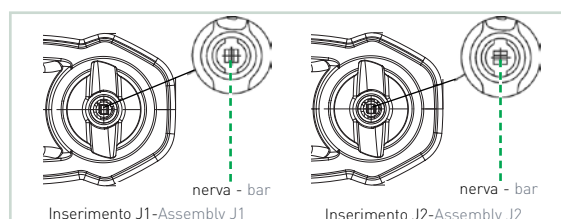

- 1 - Ruotare in senso anti orario (J1) o orario (J2) il "quadro" sul fondo dello statore sino a fine corsa
- 2 - Inserire la serratura con la lamella rivolta verso lo scivolo (ulteriori info pag. A3), previo ingrassaggio preliminare
- 1 - Turn anti clockwise (J1) or clockwise (J2) the "square" at the bottom of the stator until end-stroke position
- 2 - Insert the lock as shown with the fin facing the chute (more info at pag. A3), after preliminary greasing

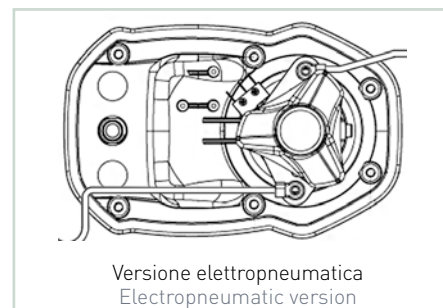
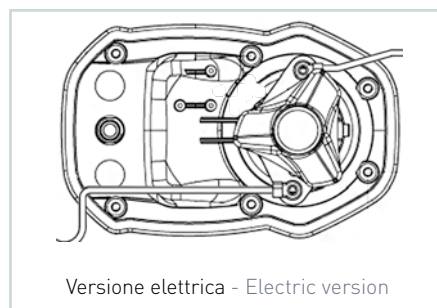
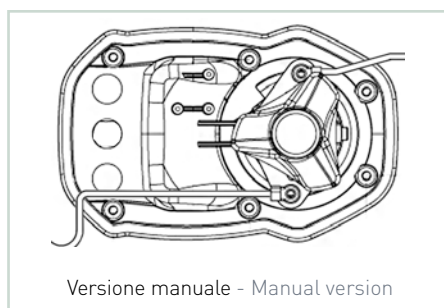

■ Schema chiusura pneumatica - Pneumatic diagram Sez. B pag B9

■ Esempi d'applicazione - Examples of application

