

Maniglia porte passeggeri - Passengers' door handle





P.230

-  **Materiale - Material**
Poliammide fibra vetro + anti-UV
Glass fibre polyamide + anti-UV
-  **Colore - Colour**
Nero - Black
-  **Pezzi confezione - Package items**
10 pezzi - pieces
-  **Volume confezione - Package volume**
24,3 dm³
-  **Peso confezione - Package weight**
P.230m, mJ1 = 3.800 g
P.230e, epn, epnJ1 = 4.600 g
P.230eJ1, eJ2 = 4.150 g

SPO **Ricambi - Spare parts only**
vedi sez. tecnica - see technical section









 **Accessori - Accessories**
vedi sez. tecnica - see technical section

 **Carico di rottura a 20°C - Breakup load at 20°C**
-

 **Temp. di esercizio - Working temp.**
-10/+120 °C

LEX **Normative - Norms**
R107.8; R118.3; FMVSS 302; ISO 3795; REACH; ROHS; CMR.
More info on page A4-A5 and website on "Directives and regulations" area.



P.230	m epn e		
	manual	electropneumatic	electric
	Cod.	Cod.	Cod.
A1 - 137	61478	66878	67977
A2 - 146	62078		68737
A3 - 150	62088		68747
A4 - 124	62098		68757
A5 - 501	62108		68767
A6 - 502	62118		68777
A7 - 250	62128		68787
A8 - 262	62138		68797
A9 - 269	62148		68807
A10 - 278	62158		68817
A11 - 156	67918		61928
A12 - 142	67928		61938
A13 - 503	67938		63818
A14 - 504	67948		63828
A15 - 505	67958		63838
A16 - 506	67968		63848
A17 - 507	67978		63858
A18 - 508	62648		63868
A19 - 509	67988		63878
A20 - 510	67998		63888
A21/A40			
J1	 65409	65399	63959
	 64631*	64621*	64641*
J2	 64631*		66109
	 64631*		64611*

P.230			elettrica con ritorno autom. pomello interno	
P.230			electric with automatic return of doorknob	
		Cod.		
J1		69171	4.150	

 **versione con serratura, chiave rimovibile con maniglia chiusa**
version with lock, removable key with locked handle

J1-J2 Sez. Tecnica (inserimento P.474) - Technical section (assembly P.474)

 **versione a richiesta - version available on request**

*Maniglia con pomello rosso anziché nero - Handle with red knob instead of black

P.230

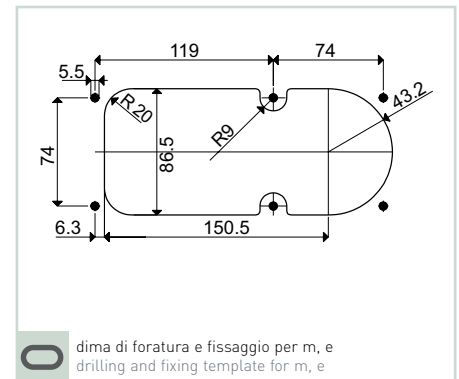
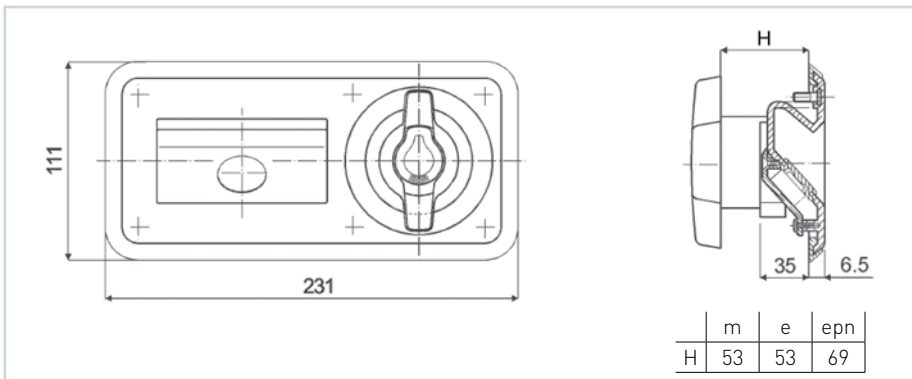

■ Inserimento - Assembly P.474 for J1

- 1 Verificare corretta posizione nerva (verticale)
- 1*Se non OK, ruotare in senso anti-orario il "quadro" sul fondo dello statore sino a fine corsa
- 2 Inserire la serratura con la lamella rivolta verso lo scivolo (ulteriori info pag.A3), previo ingrassaggio preliminare - Chiave removibile solo con maniglia chiusa

- 1 Check if bar is in "vertical" position
- 1*If not, turn the "square" at the bottom of the stator, anti-clockwise until it rest
- 2 Insert the lock as shown with the fin facing the chute (more info page A3), after preliminary greasing - Removable key with locked handle

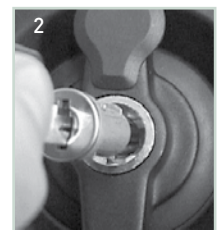
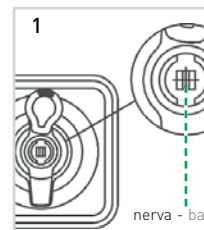

■ Inserimento - Assembly P.474 for J2

- 3 Verificare corretta posizione nerva (orizzontale)
 - 3*Se non OK, ruotare in senso orario il "quadro" sul fondo dello statore sino a fine corsa
 - 4 Inserire la serratura con la lamella rivolta verso lo scivolo (ulteriori info pag.A3), previo ingrassaggio preliminare - Chiave removibile solo con maniglia chiusa
- 3 Check if bar is in "orizzontal" position
 - 3*If not, turn the "square" at the bottom of the stator, clockwise until it rest
 - 4 Insert the lock as shown with the fin facing the chute (more info page A3), after preliminary greasing - Removable key with locked handle

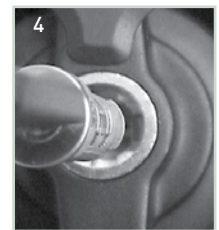
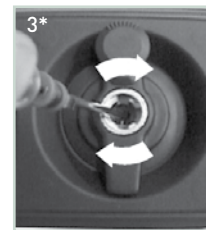
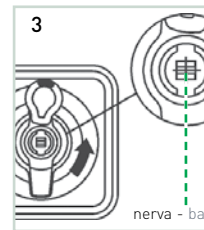

■ Schemi chiusura pneumatica ed elettrica - Pneumatic and electric diagram

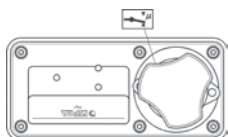

P.230 manuale: è predisposta di un micro-interruttore sull'impugnatura che permette all'autista di individuare se la porta è aperta o chiusa. No cablaggi.

Manual P.230: is equipped with a microswitch onto the handgrip, thus enabling the driver to check whether the door is opened or closed.

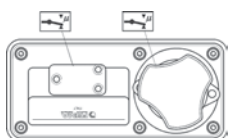

P.230 elettrica: oltre al micro sull'impugnatura, ha un secondo micro sotto al tasto tondo in PVC, che permette di aprire la portiera dall'esterno. Fornita di apposito cablaggio.

Electric P.230: in addition to the micro onto the handgrip, has a second micro under the button round PVC, which allows to open the door from the outside. Equipped with proper wiring.

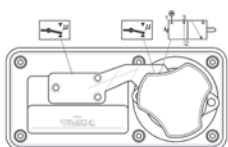

P.230 elettropneumatica: oltre ai due micro sopra citati, ha un terzo micro pneumatico attivato quando la maniglia viene azionata dall'interno. Fornita di apposito cablaggio.

Electropneumatic P.230: In addition to the two above-mentioned micro, has a third micro pneumatic activated when the handle is operated from the inside. Equipped with proper wiring.

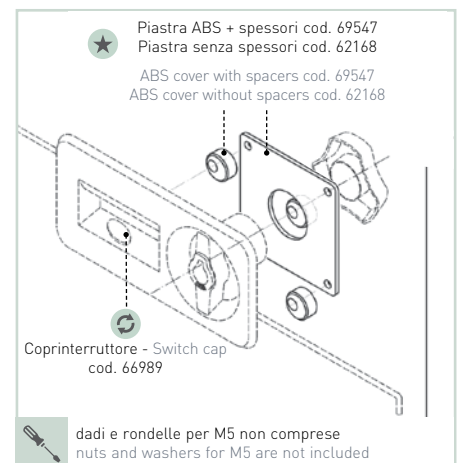

■ Esempi d'applicazione - Examples of application

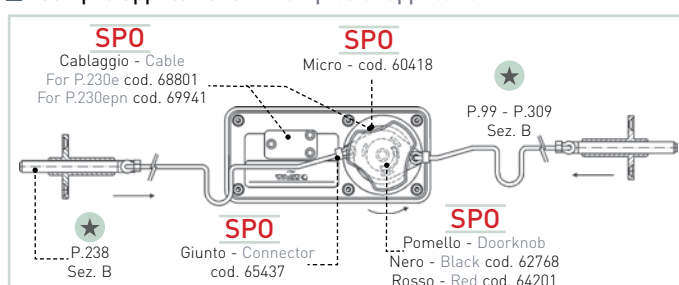

■ P.230 m, e, epn

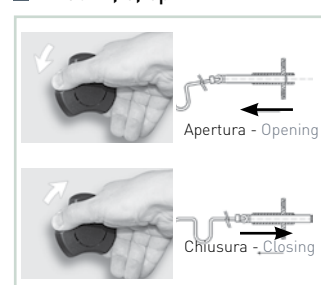

■ P.230 (cod. 69171)

