

Maniglia porte passeggeri - Passengers' door handle

P.216

Materiale - Material
 Poliammide fibra vetro + anti-UV, Acciaio Zincato
 Glass fibre polyamide + anti-UV, Zinc Plated Steel

Colore - Colour
 secondo codice - according to item code

Pezzi confezione - Package items
 20 pezzi - pieces

Volume confezione - Package volume
 7,0 dm³

Peso confezione - Package weight
 2.800 g

SPO Ricambi - Spare parts only
 vedi sez. tecnica - see technical section

★ Accessori - Accessories
 vedi sez. tecnica - see technical section

Carico di rottura a 20°C - Breakup load at 20°C
 -

Temp. di esercizio - Working temp.
 -10/+120 °C

LEX Normative - Norms
 R107.8; R118.3; FMVSS 302; ISO 3795; REACH; ROHS; CMR.
 More info on page A4-A5 and website on "Directives and regulations" area.



P.216		m manual	
	Cod.	Nero - Black	Rosso - Red
A1 - 137	60768	•	
	66721		•
A2 - 146	66967	•	
A3 - 150	60688	•	
A4 - 124	60698	•	
A5 - 501	60708	•	
A6 - 502	60718	•	
A7 - 250	60728	•	
A8 - 262	60738	•	
A9 - 269	60748	•	
A10 - 278	60758	•	
A11 - 156	63821	•	
A12 - 142	63831	•	
A13 - 503	63841	•	
A14 - 504	63851	•	
A15 - 505	63861	•	
A16 - 506	63871	•	
A17 - 507	63881	•	
A18 - 508	63891	•	
A19 - 509	63901	•	
A20 - 516	63511	•	

P.216		m manual	
	Cod.	Nero - Black	Rosso - Red
A21 - 511	63911	•	
A22 - 512	63491	•	
A23 - 513	60811	•	
A24 - 514	63921	•	
A25 - 515	62281	•	
A26 - 516	63041	•	
A27 - 517	63931	•	
A28 - 518	63941	•	
A29 - 519	63951	•	
A30 - 520	63331	•	
A31/A40		•	
A44 - 149	63631	•	
A46 - 151	64111	•	
	67737	•	

versione con serratura, chiave rimovibile con maniglia chiusa e aperta
 version with lock, removable key with both locked and unlocked handle

versione a richiesta - version available on request

P.216

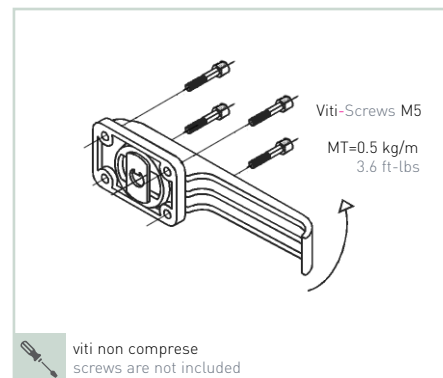
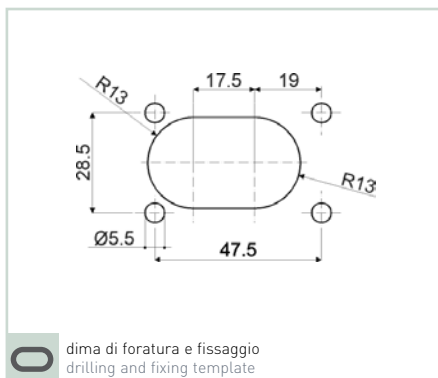
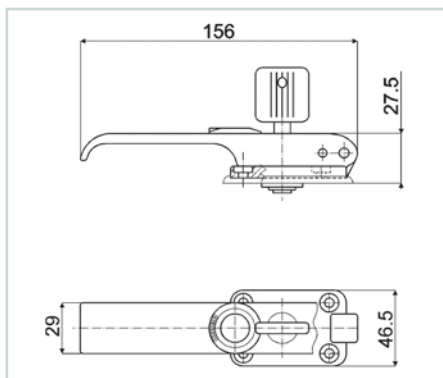

■ Esempi d'applicazione - Examples of application

Da utilizzare in abbinamento con le serrandole P.214 - Sez. B. La P.216 sul lato esterno delle porte di emergenza bus e le P.214 all'interno
To be used together with locking gear P.214 -Sec. B. The handle P.216 on the external side of emergency bus doors and P.214 inside

