

Maniglia per portelloni - Luggage door handles

P.178

Materiale - Material
 Poliammide fibra vetro + anti-UV, Inox, Ottone
 Glass fibre polyamide + anti-UV, Stainless Steel, Brass

Colore - Colour
 Nero - Black

Pezzi confezione - Package items
 25 pezzi - pieces

Volume confezione - Package volume
 64 dm³

Peso confezione - Package weight
 P.178 m - pn - e - (all versions) = 18.000 g

SPO Ricambi - Spare parts only
 vedi sez. tecnica - see technical section

★ Accessori - Accessories
 vedi sez. tecnica - see technical section

Carico di rottura a 20°C - Breakup load at 20°C
 In apertura - Opening = 2.296 N
 In chiusura - Closing = 2.740 N

Temp. di esercizio - Working temp.
 -10/+120 °C

LEX Normative - Norms
 R107.8; R118.3; FMVSS 302; ISO 3795; REACH (SCIP number at page A4-A5);
 ROHS; CMR.
 More info on page A4-A5 and website on "Directives and regulations" area.



| P.178 | m manual | pn pneumatic | e P187 actuator needed | Min |
|-----------|-------------|-----------------|---------------------------|-----|
| 🔑 | Cod. | Cod. | Cod. | |
| A1 - 137 | 69587 | 69267 | 65708 | 500 |
| A2 - 146 | 69597 | 69277 | | 500 |
| A3 - 150 | 69607 | 69287 | | 500 |
| A4 - 124 | 69617 | 69297 | | 500 |
| A5 - 501 | 69627 | 69307 | | 500 |
| A6 - 502 | 69637 | 69317 | 🔒 | 500 |
| A7 - 250 | 69647 | 69327 | | 500 |
| A8 - 262 | 69657 | 69337 | | 500 |
| A9 - 269 | 69667 | 69347 | | 500 |
| A10 - 278 | 69677 | 69357 | | 500 |
| A11/A40 | 🔒 | 🔒 | | 500 |
| J1 | 64869 | 64879 | 69899 | 100 |
| J2 | 66139 | 🔒 | No | 100 |

lotto minimo d'acquisto - minimum purchasing lot

serratura già inserita, chiave rimovibile con man. chiusa e aperta (m, pn) o solo chiusa (e)
 lock already fitted, key removable with locked and unlocked handle (m, pn) or only locked (e)

J1-J2 Sez. Tecnica (inserimento P.474) - Technical section (assembly P.474)

versione a richiesta - version available on request

P.178

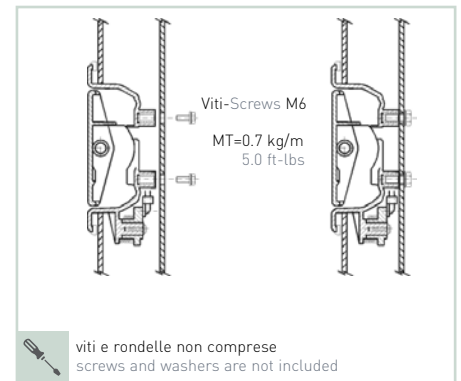
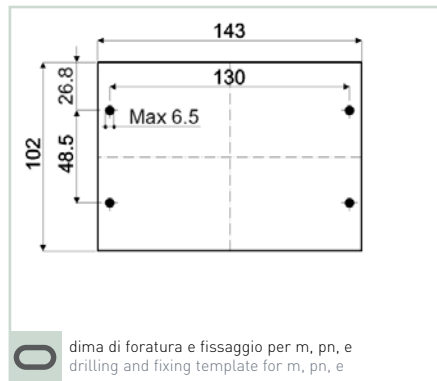
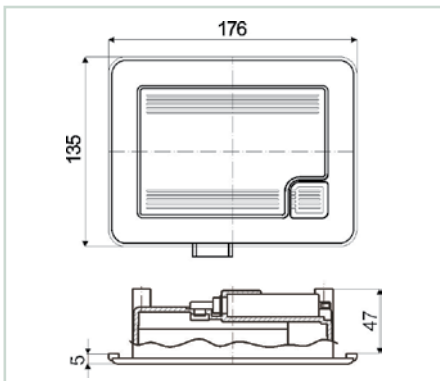

■ Inserimento - Assembly P.474 for J1m, J1pn, J1e

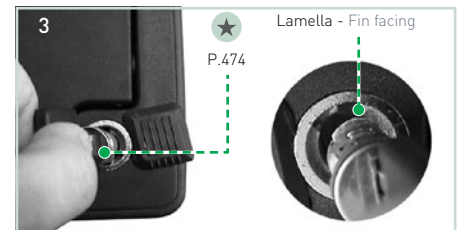
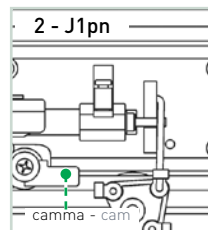
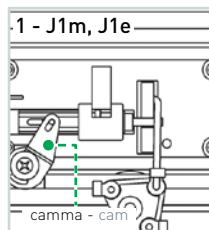

- 1, 2 Verificare corretta posizione camma * Se non OK, ruotare in senso anti-orario il "quadro" sul fondo dello statore sino a fine corsa
- 3 Inserire la serratura con la lamella rivolta verso lo scivolo (ulteriori info pag.A3), previo ingrassaggio preliminare - Chiave removibile solo con maniglia chiusa
- 1, 2 Check if cam is in "closed" position * If not, turn the "square" at the bottom of the stator, anti-clockwise until end-stroke position.
- 3 Insert the lock as shown with the fin facing the chute (more info page A3), after preliminary greasing - Removable key only with locked handle

■ Inserimento - Assembly P.474 for J2m

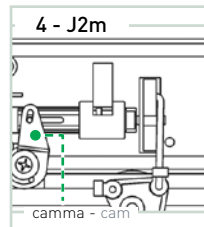

- 4 Verificare corretta posizione camma * Se non OK ruotare in senso orario il "quadro" sul fondo dello statore sino a fine corsa.
- 5 Inserire la serratura con la lamella rivolta verso lo scivolo (ulteriori info pag.A3), previo ingrassaggio preliminare - Chiave removibile sia con maniglia chiusa che aperta
- 4 Check if cam is in "open" position. - * if not, turn the "square" at the bottom of the stator, clockwise until end-stroke position..
- 5 Insert the lock as shown with the fin facing the chute (more info page A3), after preliminary greasing - Removable key with locked and unlocked handle

■ Schema chiusura pneumatica - Pneumatic diagram Sez. B pag B9

■ Esempi d'applicazione - Examples of application

